



Inline sample preparation for the determination of anions in sodium hydroxide

Authors

Hua Yang and Jeff Rohrer

Thermo Fisher Scientific,
Sunnyvale, CA, USA

Keywords

Sample preparation, matrix elimination, neutralization, process control, QC, chlor-alkali process, high pH sample, IonPac AS23-4 μ m, Guardcap H, suppressor, RFIC

Goal

Develop an easier and better method to determine mg/L concentrations of anions in sodium hydroxide by updating Application Note 51 using Thermo Scientific™ Dionex™ Guardcap™ H vial caps.

Introduction

Determination of anions in high pH samples is important for a variety of industries. For example, manufacturers of caustics need an accurate method to monitor the concentration of chlorate and other anions in the chlor-alkali process. In chlor-alkali processes, chlorine and sodium hydroxide are produced by the electrolysis of a saturated brine solution. A diaphragm is employed to separate the chlorine generated at the anode and the caustic soda produced at the cathode. Without the diaphragm to isolate the solutions, the chlorine and caustic would react and eventually produce sodium chlorate. Monitoring the chlorate, which results from sodium hydroxide coming into contact with chlorine gas, is critical to ensure the process is working correctly.

However, anions in a high pH sample cannot be determined without proper sample pretreatment due to the high hydroxide concentration in the sample, which can act as an eluent. Application Note (AN51) demonstrated a method to determine anions in sodium hydroxide after manual sample pretreatment with Thermo Scientific™ Dionex™ OnGuard™ II H cartridges.¹

This new application shows an easier method to determine mg/L concentration of anions in sodium hydroxide using automated inline sample preparation with Dionex Guardcap H vial caps. Used with a Thermo Scientific™ Dionex™ PolyVial™ in a Thermo Scientific™ Dionex™ AS-DV Autosampler, the Dionex Guardcap H vial caps serve as a cation exchange cartridge to neutralize samples and to remove metals from the samples before loading to the analytical column (Figure 1).

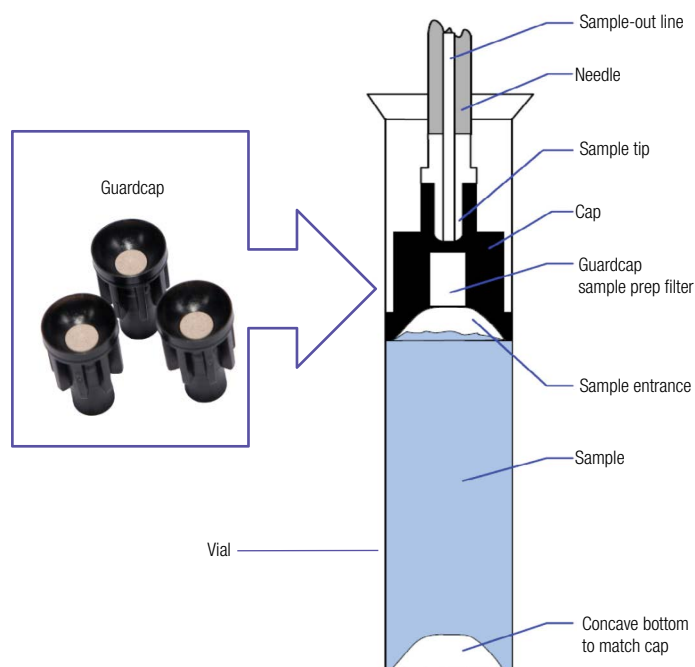

Figure 1. Illustration of the Dionex Guardcap H vial cap with Dionex PolyVial for AS-DV autosampler.

Other new technologies and products used in this application include the following: Thermo Scientific™ Dionex™ IonPac™ AS23-4µm column, Thermo Scientific™ Dionex™ EGC 500 K₂CO₃ Carbonate Eluent Generator Cartridge, and Thermo Scientific™ Dionex™ AERS™ 500 Carbonate Anion Electrolytically Regenerated Suppressor for Carbonate Eluents. If determination of µg/L concentrations of anions in caustic solution is required, please see Application Note 93.²

Experimental Equipment

- Thermo Scientific™ Dionex™ ICS-5000+ Reagent-Free Ion Chromatography (RFIC) HPIC™ System* equipped with the following for carbonate/bicarbonate eluent generation and suppression:
 - Thermo Scientific™ Dionex™ EGC 500 K₂CO₃ Carbonate Eluent Generator Cartridge
 - Dionex™ EPM 500 Electrolytic pH Modifier
 - Dionex™ EGC 500 Carbonate Mixer Kit, 4 mm
 - Thermo Scientific™ Dionex™ AERS™ 500 Carbonate Anion Electrolytically Regenerated Suppressor for carbonate eluents, 4 mm
- Thermo Scientific™ Dionex™ AS-DV Autosampler (P/N 068907) with 70 cm sample transfer line (P/N 22120-60055) and 5.0 mL vial holder (P/N 068947).

*Equivalent results can be achieved using the Thermo Scientific™ Dionex™ Integrion™ HPIC™ system.

Consumables

Table 1 lists the consumable products needed.

Table 1. Consumables list.

Product Name	Description	Part Number
Dionex™ EGC 500 K ₂ CO ₃ Carbonate Eluent Generator Cartridge	Eluent generator cartridge	088453
Dionex EPM 500 Electrolytic pH Modifier	pH Modifier	088471
Dionex™ EGC 500 Carbonate Mixer Kit, 4 mm	Carbonate Mixer Kit	088468
Thermo Scientific™ Dionex™ AERS™ 500 Carbonate Anion Electrolytically Regenerated Suppressor for Carbonate Eluents (4 mm)	Anion Electrolytically Regenerated Suppressor, 4 mm, for carbonate/bicarbonate eluents up to 15 mM	085029
Dionex High Pressure RFIC ⁺ Eluent Degasser	RFIC ⁺ eluent degasser	075522
Dionex IonPac AG23-4µm Column, 4 mm	Guard column, 4 × 50 mm	302556
Dionex IonPac AS23-4µm Column, 4 mm	Separator column, 4 × 250 mm	302555
Thermo Scientific™ Dionex™ IC Viper™ Fitting Tubing Assembly Kits	Dionex Viper Fitting Kit for Dionex Integrion System configured for eluent generation and conductivity detection. Includes one each of P/Ns: 088805–088811	088798
Thermo Scientific™ Nalgene™ Syringe Filter	Syringe filters, 25 mm, PES membrane, 0.2 µm	Thermo Scientific 725-2520 / Fisher Scientific 09-740-113
Dionex™ Guardcap™ H Vial Caps	H ⁺ -Functionalized Vial Cap, 5 mL, for use with 5 mL Dionex PolyVials, Package of 125	302504
70 cm Reduced Volume Sample Transfer Line Assembly	Recommended for use with injection valves mounted in IC systems	22120-60055
PolyVials	PolyVial, 5 mL, Package of 250	038008
Plain Cap	Vial Cap, plain, no filter, 5 mL, Package of 250	039528
Plastic Bottle	Nalgene™ Narrow-Mouth PPCO Economy Bottles with Closure, 125 mL, Case of 72	Thermo Scientific 2087-0004
Tool, Insertion	Use for Vial Cap insertion	037987

Software

Thermo Scientific™ Chromeleon™ Chromatography Data System (CDS) software, version 7.2 SR4

Reagents, samples and standards

- Deionized (DI) water, Type I reagent grade, 18 MΩ·cm resistivity or better
- Sodium or potassium salts, A.C.S. reagent grade or better, for preparing anion standards
- Thermo Scientific Dionex Stock Solutions:
 - Combined Five Anion Standard (Thermo Scientific P/N 037157)

- Fluoride Standard (Thermo Scientific P/N 037158)
- Chloride Standard (Thermo Scientific P/N 037159)
- Sulfate Standard (Thermo Scientific P/N 037160)
- Combined Seven Anion Standard (Thermo Scientific P/N 056933 or P/N 057590)
- Sodium hydroxide solution (50% w/w/Certified) (Fisher Scientific, P/N SS254-500)
 - S1: Lot # 107305
 - S2: Lot # 154087

Conditions	
Columns:	Dionex IonPac AG23-4µm, and Dionex IonPac AS23-4µm, 4 mm (i.d.) column set
Eluent:	4.5 mM K ₂ CO ₃ /0.8 mM KHCO ₃
Eluent Source:	Dionex EGC 500 K ₂ CO ₃ Cartridge with Dionex EPM 500, Dionex carbonate mixer, and Dionex high pressure RFIC ⁺ eluent degasser
Flow Rate:	1.0 mL/min
Delivery Speed:	AS-DV, 1.0 mL/min
Delivery Volume:	AS-DV, 350 µL
Injection Volume:	100 µL (Full loop)
Column Temperature:	30 °C
Detection:	Suppressed conductivity, Dionex AERS 500 Carbonate, 4 mm, 30 °C, 32 mA, recycle mode
Background:	< 17.5 µS
Noise:	< 2 nS
Backpressure:	~ 3200 psi
Run Time:	25 min

Preparation of standards and reagents

Stock standard solutions

Prepare 1000 ppm stock standard solutions of fluoride, chlorite, bromate, chloride, nitrite, chlorate, bromide, nitrate, phosphate, and sulfate by accurately weighing the amounts of reagent-grade salts provided in Table 2, and dissolving the salt in 100 g of DI water in a 125 mL polypropylene bottle. Use Thermo Scientific Stock Solutions as available. Stock standard solutions are stored in plastic containers at 4 °C. The chlorite standard is stable for two weeks. The nitrite and phosphate standards are stable for one month. The other stock standards are stable for three months.

Table 2. Mass of compound required to prepare 100 mL of a 1000 ppm solution.

Anion	Compound*	Mass (g)
Fluoride	Sodium fluoride (NaF)	0.221
Chlorite	Sodium chlorite (NaClO ₂)	0.134
Bromate	Sodium bromate (NaBrO ₃)	0.180
Chloride	Sodium chloride (NaCl)	0.165
Nitrite	Sodium nitrite (NaNO ₂)	0.150
Chlorate	Sodium chlorate (NaClO ₃)	0.128
Bromide	Sodium bromide (NaBr)	0.129
Nitrate	Sodium nitrate (NaNO ₃)	0.137
Sulfate	Sodium sulfate (Na ₂ SO ₄)	0.148
Phosphate	Sodium phosphate, monobasic (NaH ₂ PO ₄)	0.124

*Compound must be dry.

Working standard solutions

Prepare working standards by diluting appropriate volumes of the 1000 ppm stock standards with DI water. Prepare working standards daily if they contain less than 1 ppm of chlorite and nitrite.

Prepare seven levels of mixed calibration standards for determining nine anions. The highest concentration mixed standard stock is prepared first. In a 125 mL polypropylene bottle, add 0.200 mL of fluoride, 1.000 mL each of bromate, chloride, chlorate, nitrite, bromide and sulfate, and 2.000 mL of phosphate stock solutions, and then add DI water to a final volume of 100 mL (100.0 g on a top loading balance). Dilute this standard with DI water as shown in Table 3 to make the remaining mixed standards. Final concentrations are shown in Table 3.

Prepare a different set of calibration standards for chlorite. Chloride is the major impurity in sodium chlorite solid. Therefore, chlorite and chloride should not be simultaneously included in a mixed calibration standard. Adding chlorite into the mixed calibration standards listed in Table 3 will result in an incorrect amount of chloride. Make chlorite calibration standards using similar procedures. Add 1.000 mL of chlorite 1000 ppm stock solution into 99.00 mL of DI water to make a high concentration standard. Dilute it as shown in Table 4 to make the other calibration standards.

Table 3. Seven levels of mixed calibration standards for determining nine anions (ppm).

Dilution of Mixed Stock	1:1000	1:100	1:20	1:10	1:5	1:2	No Dilution
	Level 1	Level 2	Level 3	Level 4	Level 5	Level 6	Level 7
Fluoride	0.002	0.02	0.1	0.2	0.4	1	2
Bromate	0.01	0.1	0.5	1	2	5	10
Chloride	0.01	0.1	0.5	1	2	5	10
Nitrite	0.01	0.1	0.5	1	2	5	10
Chlorate	0.01	0.1	0.5	1	2	5	10
Bromide	0.01	0.1	0.5	1	2	5	10
Nitrate	0.01	0.1	0.5	1	2	5	10
Phosphate	0.02	0.2	1	2	4	10	20
Sulfate	0.01	0.1	0.5	1	2	5	10

Table 4. Seven levels of calibration standards for determining chlorite (ppm).

Dilution	1:1000	1:100	1:20	1:10	1:5	1:2	No Dilution
	Level 1	Level 2	Level 3	Level 4	Level 5	Level 6	Level 7
Chlorite	0.01	0.1	0.5	1	2	5	10

Sample preparation

Prepare the sample by diluting the samples with DI water. The 50% w/v NaOH (19.1 N) is diluted 1:500 (0.038 N) to ensure that the capacity of the Dionex Guardcap H vial caps is not exceeded.

Spike the sample by adding the concentrated mixed standard into 50% w/v NaOH before dilution.

System preparation and configuration

Set up the Dionex AS-DV autosampler according to product manual for Dionex Guardcap H vial caps.³ Make sure a reduced volume sample transfer line is installed in the Dionex AS-DV autosampler and that the Chromeleon CDS software instrument method includes the sample

delivery flow rate set at 1 mL/min and a sample delivery volume of 350 µL. Install and condition the Dionex EGC 500 K₂CO₃ Carbonate Eluent Generator Cartridge with Dionex EPM 500 as described in the Quick Start.⁴ Install and hydrate the Dionex AERS 500 Carbonate Anion Electrolytically Regenerated Suppressor.⁵ Finish the system setup according to the product manuals and the Dionex ICS-5000+ HPIC system Operator's Manual⁶ (Figure 2). Install and condition the guard and separator columns at least 30 min prior to installing the columns in line with the suppressor.⁷ Although the data in this application update were collected with eluent generation, this method can also be executed with a manually prepared 4.5 mM Na₂CO₃/0.8 mM NaHCO₃ eluent.

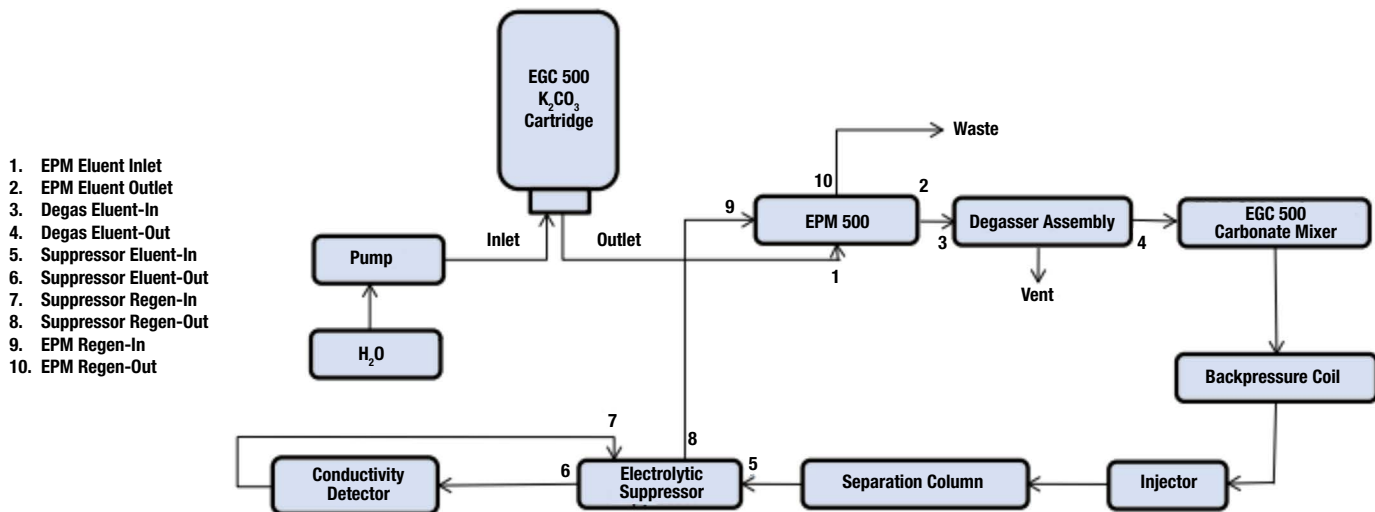

Figure 2. Flow diagram of the RFIC system.

Method detection limit calculation

The method detection limit (MDL) is defined as the minimum concentration of an analyte that can be identified, measured, and reported with 99% confidence that the analyte concentration is greater than zero. To establish the single operator, within-day MDL for each analyte, make seven replicate injections of DI water fortified with each analyte at a concentration of three to five times the estimated instrument detection limit.⁸ Here, seven replicate injections of level 1 standards, one for nine anions, and one for chlorite, are used for MDL determination. Because the sample is diluted 1:500, the MDL is multiplied by 500 to reflect the dilution.

$$MDL = 500 \times 3.14 \times \sigma$$

Results and discussion

With automated inline sample preparation using Dionex Guardcap H vial caps and electrolytic generation of eluents using a Dionex EGC 500 K₂CO₃ Eluent Generator Cartridge with a Dionex EPM 500, the determination of anions in sodium hydroxide is made simple and easy.

The 50% w/v sodium hydroxide sample required dilution with DI water before analysis. Because the capacity of a Dionex Guardcap H vial cap is lower than that of a Dionex OnGuard II H cartridge, the 1:50 dilution as used in AN51 is not sufficient for the current application. As discussed in the Dionex Guardcap H vial cap manual,³ the capacity

of the Dionex Guardcap H vial cap for metal removal and neutralization of high pH samples using the Dionex AS-DV autosampler at the flow rate of 1 mL/min is about 500 µL of 50 mM NaOH. If the alkaline concentration of the high pH sample is greater than 50 mM, the sample should be diluted before using the Dionex Guardcap H vial caps. Here, the 50% w/w NaOH (19.1 N) was first diluted 1:500 (0.038 N) to ensure the capacity of Dionex Guardcap H vial cap was not exceeded and the injection volume was increased from 25 µL to 100 µL. Note that the sample delivery volume in the instrument method is the amount of sample filtered through the Dionex Guardcap H vial cap; only part of the delivered sample is injected onto the column (injection volume), i.e., the volume of the injection loop installed on the injection valve.

The first step was to determine if inline sample preparation using Dionex Guardcap H vial caps made a difference in the anion analysis results. Figure 3 compares the chromatograms of samples of mixed anions in a high-pH matrix with and without using Dionex Guardcap H vial caps for sample preparation. The chromatogram for direct injection (without Dionex Guardcap H vial caps) gives lower efficiency and baseline disturbances compared to the treated sample, adversely affecting quantification of analytes.

Columns: Dionex IonPac AG23-4 μ m,
and Dionex IonPac AS23-4 μ m, 4 mm
Eluent: 4.5 mM K₂CO₃/0.8 mM KHCO₃
Eluent Source: Dionex EGC 500 K₂CO₃ Cartridge with Dionex EPM 500,
mixer and Dionex high pressure degasser
Flow Rate: 1.0 mL/min
Inj. Volume: 100 μ L
Column Temp.: 30 °C
Detection: Suppressed conductivity,
Dionex AERS 500 carbonate, 4 mm,
30 °C, 25 mA, recycle mode
Sample: Mixed standard in 500 \times dilution of 50% NaOH (0.0382N).
A- Inject with Dionex Guardcap H vial cap
B- Inject with plain vial cap

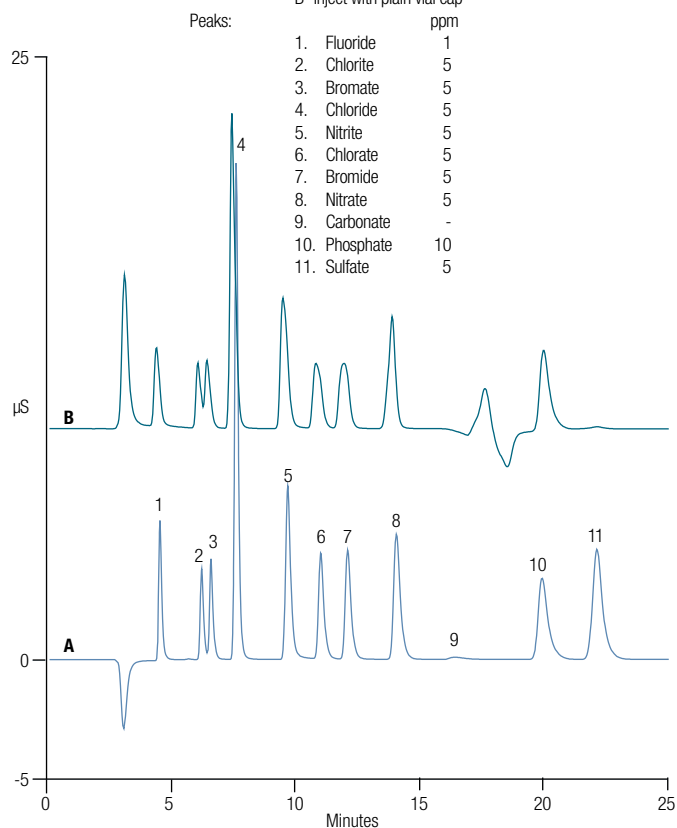

Figure 3. Improved chromatogram of mixed anions in a high-pH sample using Dionex Guardcap H vial caps for inline sample pretreatment.

Next, the effect of Dionex Guardcap H vial caps on different sample matrices was determined. The two chromatograms shown in Figure 4 were generated by treating mixed anion samples through Guardcap H vial caps. Sample A has a high pH matrix and Sample B has a deionized water matrix. Chlorite was omitted in Sample B because it is also used as the level six mixed calibration standard for anions, and addition of

Columns: Dionex IonPac AG23-4 μ m,
and Dionex IonPac AS23-4 μ m, 4 mm
Eluent: 4.5 mM K₂CO₃/0.8 mM KHCO₃
Eluent Source: Dionex EGC 500 K₂CO₃ Cartridge with Dionex EPM 500, mixer and
Dionex high pressure degasser
Flow Rate: 1.0 mL/min
Inj. Volume: 100 μ L
Column Temp.: 30 °C
Detection: Suppressed conductivity,
Dionex AERS 500 carbonate, 4 mm,
30 °C, 25 mA, recycle mode
Sample : Mixed standard treated with
Dionex Guardcap H
A- in 500 \times diluted NaOH (0.0382N)
B- in DI water

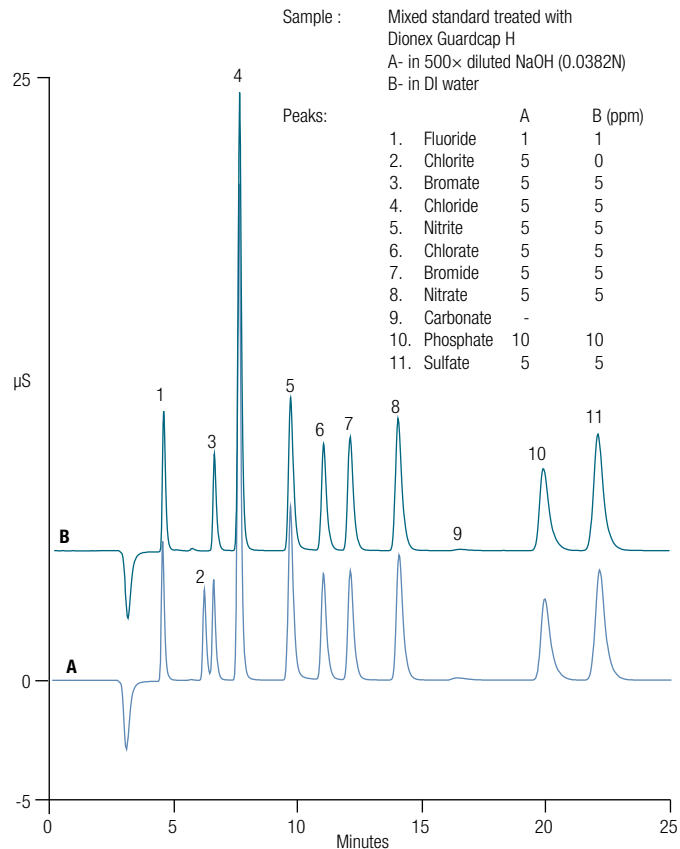

Figure 4. Chromatograms of mixed anions samples in high-pH and in neutral matrices.

chlorite will result in incorrect chloride determination. The two chromatograms are almost identical in terms of retention time, peak shape, peak response, and peak efficiency. This indicates that the adverse high-pH effect on determination of anions is completely reversed or neutralized by the Dionex Guardcap H vial caps; the correct concentration of anions in a sodium hydroxide solution can be easily determined without manual neutralization.

Before conducting sample analyses, calibration and performance of the method were demonstrated. Table 5 shows the method linearity, retention time precision, and detection limit (MDL). For the measured range, the method is linear for all anions ($r^2 \geq 0.997$). The linear calibrations for all anions were also demonstrated

by their calibration plots (Figure 5). The retention times are precise (RSDs < 0.1 with the exception of sulfate < 0.2). The MDLs were determined by injecting level 1 mixed standards (n = 7). The method is sensitive with MDL < 3 ppm for most anions.

Table 5. Method linearity, retention time precision, and detection limit (MDL).

Analyte	Calibration Range (ppm)	Coefficient of Determination (r^2)	Retention Time Precision (RSD) *	MDL Standard (ppm)	MDL** (ppm)
Fluoride***	2-0.02	0.999	<0.1	0.002	2
Chlorite	10-0.01	0.998	<0.1	0.01	3
Bromate	10-0.01	1.000	<0.1	0.01	2
Chloride	10-0.01	0.997	<0.1	0.01	1
Nitrite	10-0.01	1.000	<0.1	0.01	1
Chlorate	10-0.01	0.999	<0.1	0.01	2
Bromide	10-0.01	0.999	<0.1	0.01	2
Nitrate	10-0.01	0.997	<0.1	0.01	1
Phosphate	20-0.02	0.999	<0.1	0.02	3
Sulfate	10-0.01	0.999	<0.2	0.01	2

*RSD = relative standard deviation of 7 levels, n = 3 for each level.

** For 100 μ L injection and 500 fold sample dilution, MDL = $500 \times 3.14 \times \sigma$ when n = 7.

*** MDL of fluoride is determined by the signal to noise ratio (S/N) of the level 2 standard.

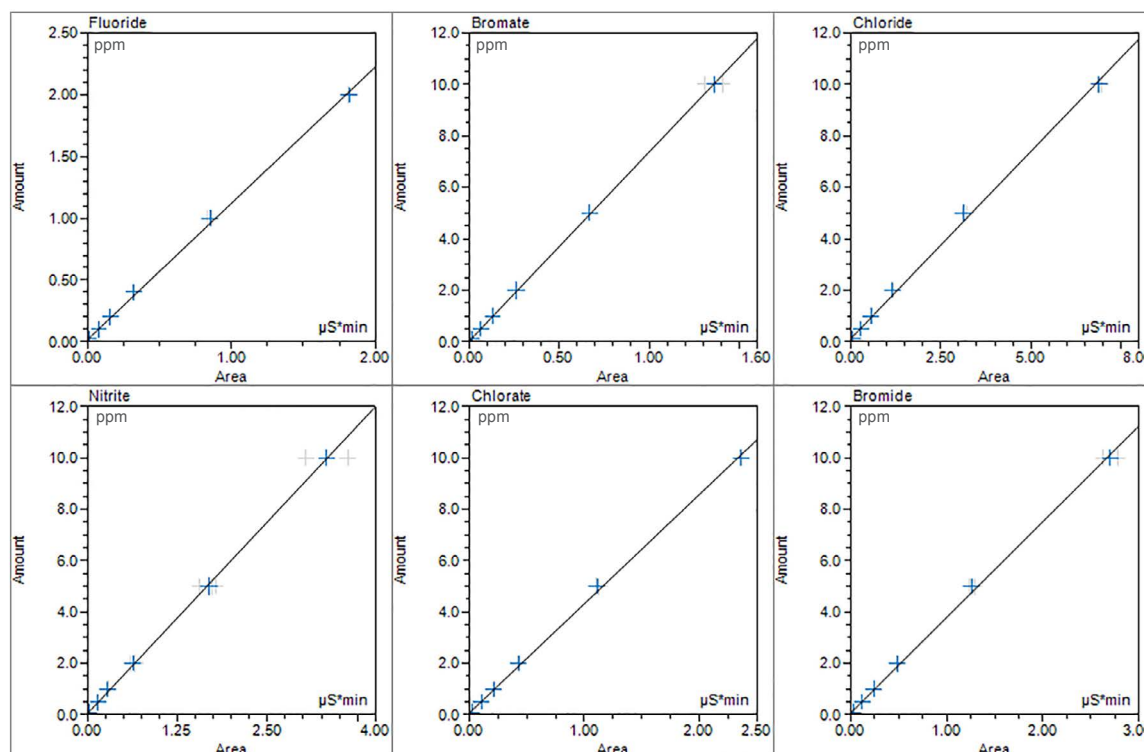

Figure 5A. Calibration plots illustrating linearity.

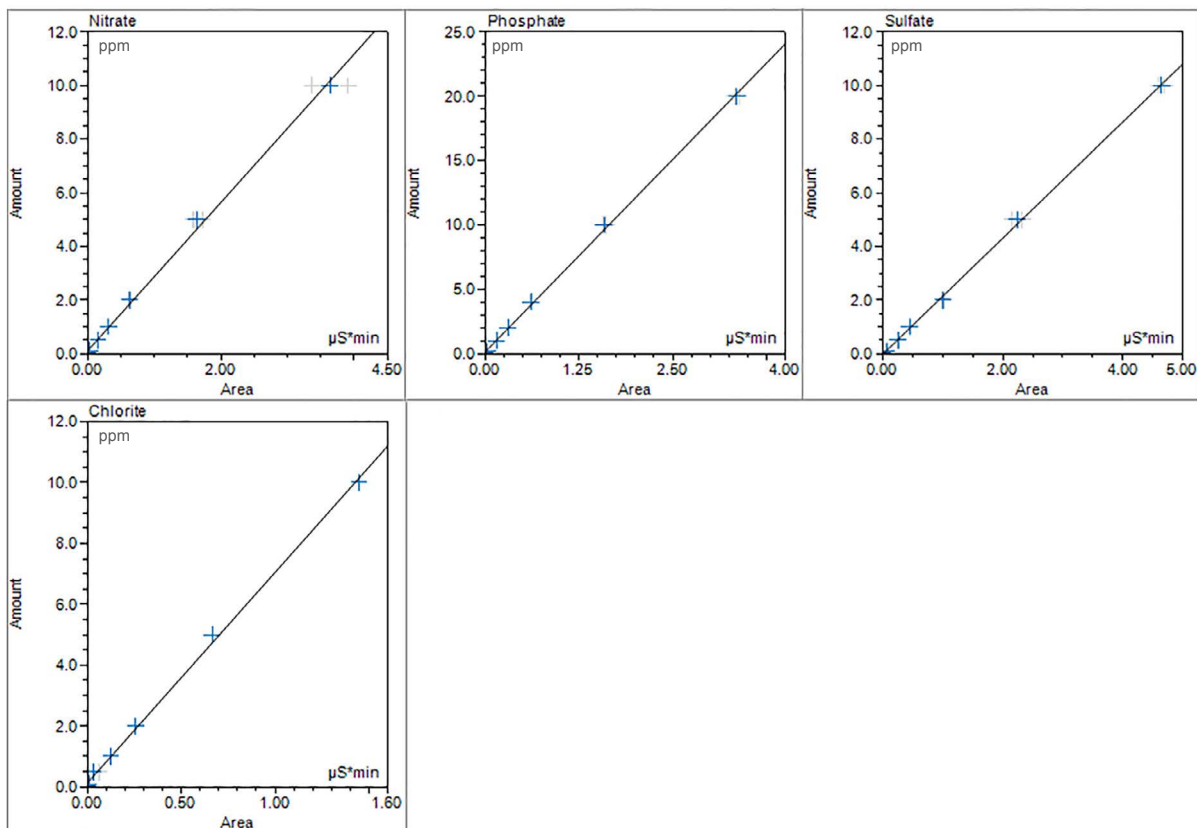

Figure 5B. Calibration plots illustrating linearity.

The method performance was measured by determining recovery of spiked samples. Table 6 shows analyte amounts found in two different lots of 50% w/v NaOH, S1 and S2, and recovery of 10 ppm anions spiked into these two samples. The recoveries for chlorite, bromate,

chloride, nitrite, chlorate, and bromide are from 71% to 127%. The relatively large range of recovery is reasonable for such a low level spike. These spikes are close to the low detection range at about 5 to 10 times the MDL. The method is accurate.

Table 6. Recovery of 10 ppm of chlorite, bromate, chloride, nitrite, chlorate, and bromide spiked into 50% w/w NaOH.

	Chlorite*	Bromate	Chloride	Nitrite	Chlorate	Bromide
Amount Found (ppm) in S1	<MDL	<MDL	3	<MDL	<MDL	<MDL
Recovery (%)	80	103	94	99	101	96
	109	118	112	97	127	112
	109					
Amount Found (ppm) in S2	<MDL	<MDL	2	<MDL	<MDL	<MDL
Recovery (%)		91	93	86	111	98
		107	93	83	109	100
		110	87	82	89	96
		91	89	92	104	90
	105	107	114	92	91	84
	125	107	106	100	99	71
	97	118	114	89	81	88

* Bromate, chloride, nitrite, chlorate, and bromide were spiked together using mixed anion standards. Chlorite was spiked separately.

Conclusion

This application uses a Dionex Reagent-Free Ion Chromatography (RFIC) system with Dionex Guardcap H vial caps on Dionex PolyVials for the Dionex AS-DV autosamplers to determine anions in a sodium hydroxide matrix. With automated inline sample preparation and electrolytic generation of eluents, the new method is easier and simpler compared to the method outlined in AN51, which uses the offline sample preparation cartridge, Dionex OnGuard II H. For target anions (chlorite, bromate, chloride, nitrite, chlorate, and bromide) in the measured range (5 to 5000 ppm), the method is linear ($r^2 \geq 0.997$), sensitive (MDL < 3 ppm), and accurate (recovery 71% to 127%).

References

1. Thermo Scientific Application Note 51: Method for Determination of Anions in Sodium Hydroxide. Sunnyvale, CA, 2003. [Online] http://tools.thermofisher.com/content/sfs/brochures/4657-AN51_IC_anions_NAOH_19Aug03_LPN1552.pdf (accessed Mar. 27, 2017).
2. Thermo Scientific Application Note 93: Determination of Trace Anions in Concentrated Bases Using Auto Neutralization Pretreatment and Ion Chromatography. Sunnyvale, CA, 2007. [Online] http://tools.thermofisher.com/content/sfs/brochures/4176-AN93_21May07_LPN1886-R2.pdf (accessed Mar. 27, 2017).
3. Thermo Scientific Product Manual for Dionex Guardcap H. Sunnyvale, CA, 2016. [Online] <https://tools.thermofisher.com/content/sfs/manuals/Man-065705-Guardcap-H-Vial-Caps-Man065705-EN.pdf> (accessed Mar. 27, 2017).
4. Thermo Scientific Eluent Generator Cartridge (EGC) 500 K2C03 High Pressure Electrolytic pH Modifier (EPM) 500 Quick Start. Sunnyvale, CA, 2014. [Online] <https://tools.thermofisher.com/content/sfs/manuals/QS-065084-EGC-III-K2C03-QS-065084-EN.pdf> (accessed Mar. 27, 2017).
5. Thermo Scientific Product Manual for Dionex ERS 500 Electrolytically Regenerated Suppressor. Sunnyvale, CA, 2014. [Online] <https://tools.thermofisher.com/content/sfs/manuals/Man-031956-IC-Dionex-ERS-Suppressor-Man031956-EN.pdf> (accessed Mar. 27, 2017).
6. Thermo Scientific Dionex ICS-5000+ Ion Chromatography System Operator's Manual. Sunnyvale, CA, 2014. [Online] <https://tools.thermofisher.com/content/sfs/manuals/Man-065446-IC-ICS-5000+-Operators-Manual.pdf> (accessed Mar. 27, 2017).
7. Thermo Scientific Dionex IonPac AS23-4 μ m and Dionex IonPac AG23-4 μ m Guard Column Product Manual. Sunnyvale, CA, 2016. [Online] <https://tools.thermofisher.com/content/sfs/manuals/Man-065711-IonPac-AS23-4um-Man065711-EN.pdf> (accessed Mar. 27, 2017).
8. U.S. Environmental Protection Agency. 40 CFR Appendix B to Part 136 – Definition and Procedure for the Determination of the Method Detection Limit, Revision 1.11, 2011. [Online] <https://www.gpo.gov/fdsys/pkg/CFR-2011-title40-vol23/pdf/CFR-2011-title40-vol23-part136-appB.pdf> (accessed Mar. 27, 2017)

Find out more at thermofisher.com

ThermoFisher
SCIENTIFIC